



Submittal Data Sheet

VSSI48 SQUARE IN-LINE FAN

Job Name: _____

Equipment Rep: _____

Contractor: _____

Prepared By: _____

Arch./Engr.: _____

Date: _____

Description:

VSSI Series Variable Speed Square In-line Fans are suitable for providing combustion air and/or ventilation.

Use with the CPC-3 Constant Pressure Controller, closed-loop VFD, and TD-Series Pressure Transducer for an automatic-variable speed system designed to modulate in order to always deliver the perfect amount of combustion air or ventilation. For an adjustable-fixed speed system, use an open-loop VFD to manually adjust the speed of the VSSI.

Housing Construction:

Constructed of heavy-gauge galvanized steel. Removable side panels provide access to motor assembly without removal of the duct connections.

Impeller Construction:

Backward inclined, non-overloading, aluminum wheel is statically and dynamically balanced.

Motor:

Three phase, 5 HP, 208-230/460 VAC, TEFC, E-PLUS 3, Inverter Duty Rated.

Standard Equipment:

- Motor Cover
- Vibration Isolators - Floor Mount, Neoprene
- Disconnect Switch - Unfused (NEMA 1), Shipped Loose
- PSA-1 Fan Proving Switch
- FFP-1 Fire and Freeze Protection Limit

Optional Equipment:

- CPC-3 Constant Pressure Controller
- IPS-1 Indoor Pressure Sensor with Decorative Cover Fitting
- TD-Series Pressure Transducer
- VFD-Series Variable Frequency Drive

Listings:

UL 705 - Power Venters

Temperature Rating:

120° F / 49° C

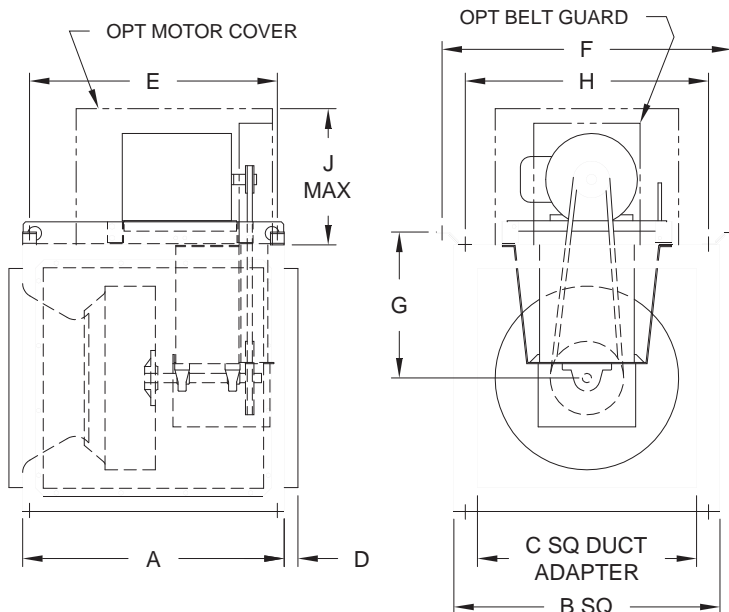

VSSI48	
Fan Type	Centrifugal
Voltage	3x230 / 3x460
Amps	13.71 / 6.20
RPM	550
Power Rating	5 HP
Weight	665 Lbs
Dimension A	48.50"
Dimension B	50.13"
Dimension C	45.88"
Dimension D	1.50"
Dimension E	46.50"
Dimension F	52.94"
Dimension G	26.44"
Dimension H	47.88"
Dimension J	20.00"
Damper Size	46.00" X 46.00"
Side Discharge Size	32.88" X 41.88"